

Part Number & Ordering Information

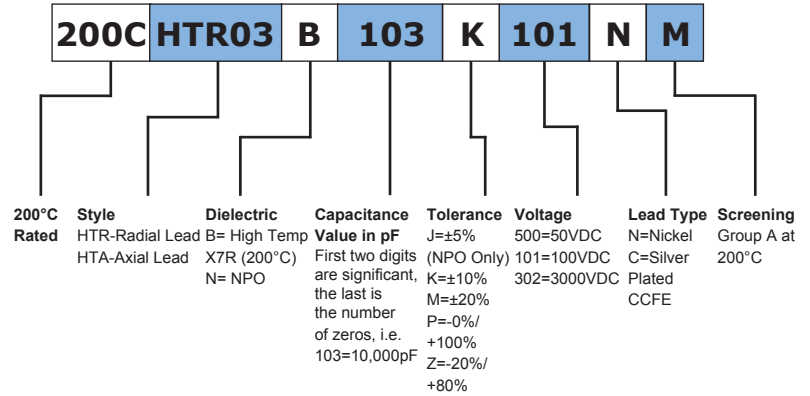

General Information

- High temperature epoxy encased
- Designed for performance and reliability
- Low stress designs
- Temperature Coefficient
 - -40% max at 200°C
 - -60% max for extended ranges on HTX7R
- Group A screening available per Mil-Prf-49467 @ 200°C
 - Voltage Conditioning at 1.5x rated voltage for 200 VDC and below
- Partial Discharge testing available for >500VDC rated

Leads

0.025" [0.65mm] 22AWG silver plated Copper-clad steel (CCFE) or solid nickel

SPECIFICATIONS	DIELECTRIC TYPE (EIA DESIGNATION)		
	NPO	HTX7R	HTX7R Extended Series
TEMPERATURE RANGE	-55°C to 200°C	-55°C to 200°C	-55°C to 200°C
TEMPERATURE COEFFICIENT	± 60 ppm/°C	+15% / -40% max	+15% / -60% max
VOLTAGE COEFFICIENT	0	-20% max	-35% max
VOLTAGE RANGE	50V to 10,000V	50V to 10,000V	50V to 10,000V
IR @ 200°C	100MΩ or 1Ω - μF whichever is less	100MΩ or 1Ω - μF whichever is less	100MΩ or 1Ω - μF whichever is less
DIELECTRIC WITHSTANDING VOLTAGE	< 200VDC @ 2x Rated ≥ 200VDC @ 1.5 Rated ≥ 1000VDC @ 1.2 Rated	< 200VDC @ 2x Rated ≥ 200VDC @ 1.5 Rated ≥ 1000VDC @ 1.2 Rated	< 200VDC @ 2x Rated ≥ 200VDC @ 1.5 Rated ≥ 1000VDC @ 1.2 Rated
DISSIPATION FACTOR @ 1kHz, 25 °C	0.1% max	2.0% max	2.0% max
AGING RATE	0	-2% max/decade hour	-2% max/decade hour
LEAD TYPE	22 GA (.025" dia.) nickel or silver plated CCFE	22 GA (.025" dia.) nickel or silver plated CCFE	22 GA (.025" dia.) nickel or silver plated CCFE

High Voltage Commercial and Military Quality Multi-Layer Ceramic Capacitors

STYLE	SIZES (MAX)				LEAD SPACING ± 0.030 INCHES [0.762 MM]
	WIDTH INCHES [MM]	HEIGHT INCHES [MM]	THICKNESS INCHES [MM]	DIAMETER INCHES [MM]	
HTR01	0.200 [5.08]	0.200 [5.08]	0.100 [2.54]	-	0.100 [2.54]
HTR02	0.200 [5.08]	0.200 [5.08]	0.100 [2.54]	-	0.200 [5.08]
HTR03	0.200 [5.08]	0.200 [5.08]	0.150 [3.81]	-	0.100 [2.54]
HTR04	0.300 [7.60]	0.300 [7.60]	0.150 [3.81]	-	0.200 [5.08]
HTR05	0.500 [12.70]	0.500 [12.70]	0.250 [6.35]	-	0.400 [10.16]
HTR06	0.700 [17.80]	0.400 [10.16]	0.250 [6.35]	-	0.500 [12.70]
HTR07	1.500 [38.10]	0.750 [19.05]	0.300 [7.62]	-	1.375 [34.93]
HTA10	0.170 [4.32]	-	-	0.100 [2.54]	-
HTA11	0.270 [6.86]	-	-	0.135 [3.43]	-
HTA12	0.400 [10.16]	-	-	0.155 [3.94]	-
HTA13	0.500 [12.70]	-	-	0.200 [5.08]	-
HTA14	0.750 [19.10]	-	-	0.375 [9.53]	-

HIGH TEMPERATURE RADIAL CAPACITORS - MAX CAPACITANCE

STYLE	50 VDC		100 VDC		200 VDC		500 VDC		1 KVDC		2 KVDC		3 KVDC		4 KVDC		5KVDC		10 KVDC	
	NPO	HT X7R	NPO	HT X7R	NPO	HT X7R	NPO	HT X7R	NPO	HT X7R	NPO	HT X7R	NPO	HT X7R	NPO	HT X7R	NPO	HT X7R	NPO	HT X7R
HTR01	5600 pF	.082 μF	4700 pF	.068 μF	3900 pF	.027 μF	1800 pF	3900 pF	560 pF	1000 pF	-	-	-	-	-	-	-	-	-	-
HTR01 Extended	-	.12 μF	-	.10 μF	-	.039 μF	-	5600 pF	-	1500 pF	-	-	-	-	-	-	-	-	-	-
HTR02	5600 pF	.082 μF	4700 pF	.068 μF	3900 pF	.027 μF	1800 pF	3900 pF	560 pF	1000 pF	-	-	-	-	-	-	-	-	-	-
HTR02 Extended	-	.12 μF	-	.10 μF	-	.039 μF	-	5600 pF	-	1500 pF	-	-	-	-	-	-	-	-	-	-
HTR03	5600 pF	.082 μF	4700 pF	.068 μF	3900 pF	.039 μF	2700 pF	6800 pF	1000 pF	1800 pF	-	-	-	-	-	-	-	-	-	-
HTR03 Extended	-	.12 μF	-	.10 μF	-	.056 μF	-	.010 μF	-	2700 pF	-	-	-	-	-	-	-	-	-	-
HTR04	.025 μF	.47 μF	.022 μF	.39 μF	.018 μF	.15 μF	.010 μF	.022 μF	3300 pF	5600 pF	560 pF	1000 pF	-	-	-	-	-	-	-	-
HTR04 Extended	-	.82 μF	-	.68 μF	-	.22 μF	-	.033 μF	-	8200 pF	-	1500 pF	-	-	-	-	-	-	-	-
HTR05	.068 μF	1.2 μF	.056 μF	1.0 μF	.047 μF	.56 μF	.033	.22 μF	.018 μF	.056 μF	3900 pF	.015 μF	2700pF	5600 pF	680 pF	2500 pF	-	-	-	-
HTR05 Extended	-	1.8 μF	-	1.5 μF	-	.82 μF	-	.33 μF	-	.082 μF	-	.022 μF	-	8200 pF	-	3900 pF	-	-	-	-
HTR06	.10 μF	1.8 μF	.082 μF	1.5 μF	.068 μF	.82 μF	.047	.33 μF	.027 μF	.082 μF	5600 pF	.018 μF	3900 pF	8200 pF	2200 pF	3900 pF	1000 pF	2200 pF	-	-
HTR06 Extended	-	2.7 μF	-	2.2 μF	-	1.2 μF	-	.47 μF	-	.12 μF	-	.027 μF	-	.012 μF	-	5600 pF	-	3300 pF	-	-
HTR07	-	-	-	-	-	-	-	-	.10 μF	.39 μF	.022 μF	.086 μF	.015 μF	.033 μF	4700 pF	.018 μF	3700 pF	.01 μF	1200 pF	2200 pF
HTR07 Extended	-	-	-	-	-	-	-	-	-	.56 μF	-	.12 μF	-	.047 μF	-	.015 μF	-	.012 μF	-	3300 pF

HIGH TEMPERATURE AXIAL CAPACITORS - MAX CAPACITANCE

STYLE	50 VDC		100 VDC		200 VDC		500 VDC		1 KVDC		2 KVDC		3 KVDC		4 KVDC		5KVDC		10 KVDC	
	NPO	HT X7R	NPO	HT X7R	NPO	HT X7R	NPO	HT X7R	NPO	HT X7R	NPO	HT X7R	NPO	HT X7R	NPO	HT X7R	NPO	HT X7R	NPO	HT X7R
HTA10	1400 pF	.027 μF	1200 pF	.022 μF	1000 pF	8200 pF	680 pF	1000 pF	180 pF	270 pF	-	-	-	-	-	-	-	-	-	-
HTA10 Extended	-	.039 μF	-	.033 μF	-	.012 μF	-	1500 pF	-	390 pF	-	-	-	-	-	-	-	-	-	-
HTA11	3300 pF	.068 μF	2700 pF	.056 μF	2500 pF	.033 μF	1800 pF	3300 pF	470 pF	680 pF	-	-	-	-	-	-	-	-	-	-
HTA11 Extended	-	.10 μF	-	.082 μF	-	.047 μF	-	4700 pF	-	1000 pF	-	-	-	-	-	-	-	-	-	-
HTA12	.01 μF	.18 μF	8200 pF	.15 μF	6800 pF	.082 μF	4700 pF	.015 μF	2200 pF	2700 pF	390 pF	560 pF	220 pF	390 pF	-	-	-	-	-	-
HTA12 Extended	-	.27 μF	-	.22 μF	-	.12 μF	-	.022 μF	-	3900 pF	-	1000 pF	-	560 pF	-	-	-	-	-	-
HTA13	-	.27 μF	-	.22 μF	-	.12 μF	-	.027 μF	-	5600 pF	-	1500 pF	-	1000 pF	-	270 pF	-	-	-	-
HTA13 Extended	-	.39 μF	-	.33 μF	-	.18 μF	-	.039 μF	-	8200 pF	-	2200 pF	-	1200 pF	-	390 pF	-	-	-	-
HTA14	-	.68 μF	-	.56 μF	-	.33 μF	-	.12 μF	-	.033 μF	-	6800 pF	-	3300 pF	-	1200 pF	-	820 pF	-	-
HTA14 Extended	-	1.0 μF	-	.82 μF	-	.47 μF	-	.18 μF	-	.047 μF	-	.01 μF	-	4700 pF	-	1800 pF	-	1200 pF	-	-