

High Voltage Radial Leaded Disc Capacitors

200°C Rated NPO & HTX7R – 3 kVdc to 20kVdc

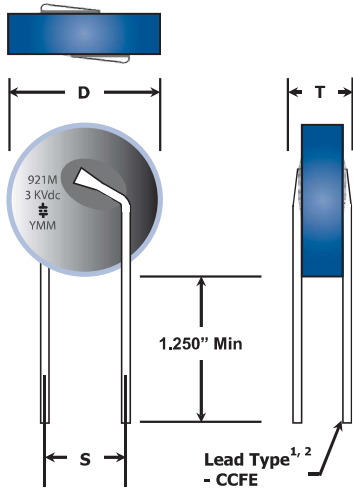

1. Lead Size: D30, D40 @ 0.025" Dia (#22 AWG) [0.64 mm] D50 & larger @ 0.032" Dia (#20 AWG) [0.81mm].
2. Lead Finish: Solder
3. Order of marking may vary depending on size of capacitor.

CalRamic Technologies LLC manufactures a series of highly reliable, single layer, leaded ceramic disc capacitors that are designed and manufactured under strict quality control guidelines to ensure unparalleled performance in high temperature, high voltage applications.

These capacitors, which draw on thirty plus years of proven design and process experience, utilize double action pressing to minimize gradients within the dielectric powder and produce a finished capacitor with a uniform fired ceramic density.

Capacitors are available with ultra stable Class I, NPO dielectrics, essential where low losses and tight capacitance tolerances are critical and stable Class II, X7R type dielectric materials, which are intended for those applications where higher losses and less precision can be tolerated.

These capacitors are ideally suited as snubbers for switching power supplies, coupling and decoupling capacitors, inverter circuitry, lighting ballasts, and other high voltage pulse applications intended for the high temperature down-hole, automotive and industrial markets.

Performance Characteristics

Specification	Dielectric Type (EIA Designation)	
	HTNPO (COG)	HTX7R
Material Classification	Type I, Ultra Stable, K76	Type II, Stable, K2350
Coefficient of Thermal Expansion	$9 \times 10^{-6} / ^\circ\text{C}$	$11 \times 10^{-6} / ^\circ\text{C}$
Density	76 g / in ³	
Operating Temperature Range	-55 to +200°C	
Aging Rate	0	-2% Max per decade hour
Temperature Coefficient	± 30 PPM / °C	+15 / -70%
Capacitance Range	1.4 pF to 350 pF	42 pF to 0.012 μF
Voltage Range	3 kVDC to 20 kVDC	
Insulation Resistance @ +25°C	100,000 M Ω or 1000 M Ω - μF , W/E is less	
Insulation Resistance @ +200°C	1000 M Ω or 10 M Ω - μF , W/E is less	
Dissipation Factor	0.1% Max	2.5% Max
DWV	1.5 x WVDC	

General Information

1. Standard inspection and Group A testing, when required, is performed in accordance with applicable requirements of MIL-PRF-49467, DSCC 87125, DSCC 89087 and NASA GSFC S-311-15C.
2. Special testing including 100% Partial Discharge (Corona) is available upon request.
3. Custom voltages, package sizes, lead configurations and capacitance values available. Contact factory.
4. Higher voltage parts may require encapsulation to prevent surface arc over and breakdown. When required, parts should first be cleaned and oven dried at +85°C. A suitable encapsulant, capable of withstanding the extreme conditions associated with these applications, may be used and de-aging of coatings is recommended.
5. Testing of higher voltage parts before installation and / or supplemental encapsulation, may be done in a suitable, non-contaminating dielectric fluid like FC-40.
6. Large ceramic capacitors, even leaded devices are susceptible to damage when exposed to thermal and / or mechanical shock. Refer to Technical Bulletin AN103/AN112 for handling and installation recommendations.

High Voltage Radial Leaded Disc Capacitors

200°C Rated NPO & HTX7R – 3 kVdc to 20kVdc

Electrical / Mechanical Characteristics

Working Voltage	Disc Style	Dimensions [in]			Capacitance Range [pF]			
		D Max	S ± 0.030	T Max	HTNPO (N)		HTX7R (X)	
					Min	Max	Min	Max
3 kVDC	D30	0.300	0.250	0.210	8.4	12	260	350
	D40	0.400	0.250	0.210	12	24	380	730
	D50	0.500	0.375	0.210	28	46	870	1400
	D60	0.600	0.375	0.210	38	61	1200	1900
	D70	0.700	0.500	0.210	63	95	2000	2900
	D80	0.800	0.500	0.210	94	110	2900	3500
	D90	0.900	0.500	0.210	110	160	3500	5000
	D100	1.000	0.500	0.210	150	200	4700	6200
	D120	1.200	0.500	0.210	200	310	6200	9500
D140	1.400	0.625	0.210	310	350	9600	12000	
5 kVDC	D30	0.300	0.250	0.250	5.1	6.9	150	210
	D40	0.400	0.250	0.250	7.3	15	230	440
	D50	0.500	0.375	0.250	17	28	520	860
	D60	0.600	0.375	0.250	23	37	700	1100
	D70	0.700	0.500	0.250	38	57	1200	1800
	D80	0.800	0.500	0.250	57	69	1800	2100
	D90	0.900	0.500	0.250	69	97	2100	3000
	D100	1.000	0.500	0.250	92	120	2900	3700
	D120	1.200	0.500	0.250	120	180	3800	5700
D140	1.400	0.625	0.250	190	230	5800	7000	
7.5 kVDC	D30	0.300	0.250	0.310	3.4	4.6	100	150
	D40	0.400	0.250	0.310	5	9.6	150	300
	D50	0.500	0.375	0.310	12	19	350	580
	D60	0.600	0.375	0.310	15	25	470	750
	D70	0.700	0.500	0.310	25	38	780	1200
	D80	0.800	0.500	0.310	37	46	1200	1400
	D90	0.900	0.500	0.310	45	65	1400	2000
	D100	1.000	0.500	0.310	60	80	1900	2500
	D120	1.200	0.500	0.310	80	120	2500	3800
D140	1.400	0.625	0.310	120	150	3800	4700	
10 kVDC	D30	0.300	0.250	0.365	2.5	3.5	78	110
	D40	0.400	0.250	0.365	3.8	7.2	110	220
	D50	0.500	0.375	0.365	8.5	14	260	430
	D60	0.600	0.375	0.365	12	18	350	560
	D70	0.700	0.500	0.365	19	28	580	880
	D80	0.800	0.500	0.365	28	34	870	1100
	D90	0.900	0.500	0.365	34	48	1000	1500
	D100	1.000	0.500	0.365	46	60	1400	1800
	D120	1.200	0.500	0.365	60	93	1900	2800
D140	1.400	0.625	0.365	94	110	2900	3500	
15 kVDC	D30	0.300	0.250	0.474	1.6	2.3	52	71
	D40	0.400	0.250	0.475	2.4	4.8	76	150
	D50	0.500	0.375	0.475	5.7	9.4	180	290
	D60	0.600	0.375	0.475	7.7	12	230	370
	D70	0.700	0.500	0.475	12	20	390	590
	D80	0.800	0.500	0.475	19	23	580	710
	D90	0.900	0.500	0.475	23	32	690	1000
	D100	1.000	0.500	0.475	30	40	950	1200
	D120	1.200	0.500	0.475	40	60	1300	1900
D140	1.400	0.625	0.475	60	77	1900	2300	
20 kVDC	D50	0.500	0.375	0.575	4.6	6.8	140	210
	D60	0.600	0.375	0.575	6.2	8.9	190	270
	D70	0.700	0.500	0.575	10	14	310	430
	D80	0.800	0.500	0.575	15	17	470	520
	D90	0.900	0.500	0.575	18	23	560	720
	D100	1.000	0.500	0.575	24	30	760	900
	D120	1.200	0.500	0.575	32	45	1000	1400
D140	1.400	0.625	0.575	50	56	1600	1700	

High Voltage Radial Ledged Disc Capacitors

200°C Rated NPO & HTX7R – 3 kVdc to 20kVdc



Part Number / Ordering Information

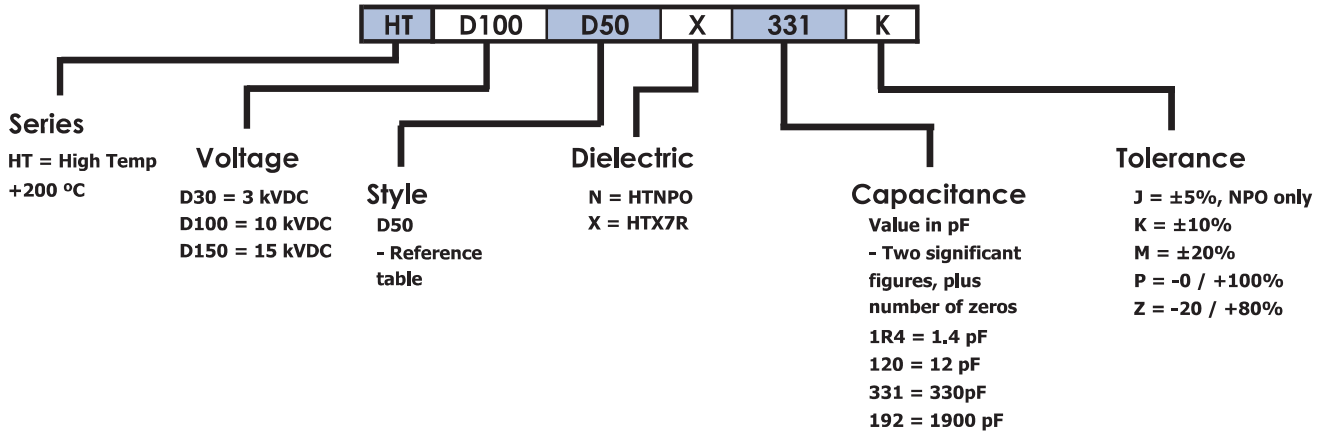

Performance Charts (Typical)

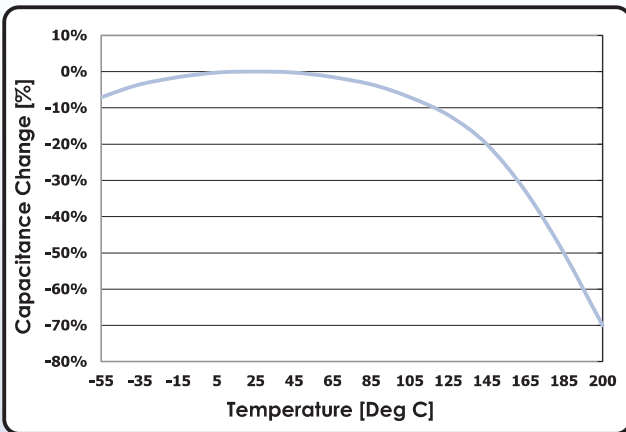

HTX7R Temperature Coefficient

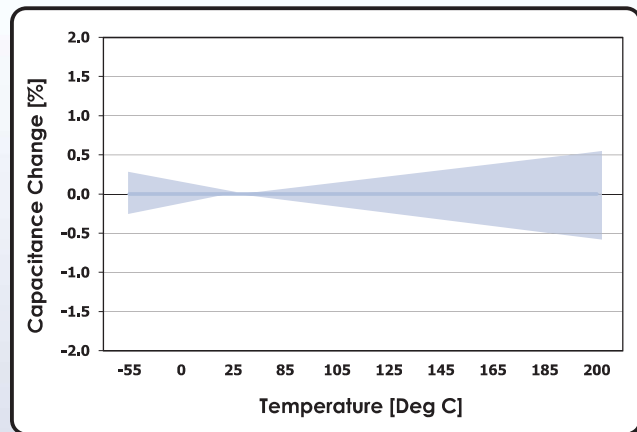

HTNPO Temperature Coefficient

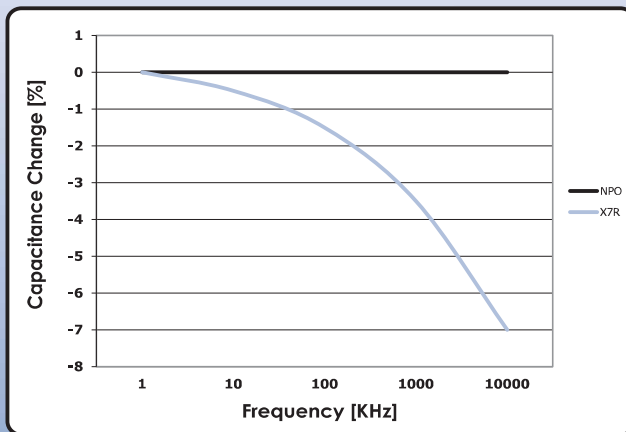

Capacitance Vs Frequency

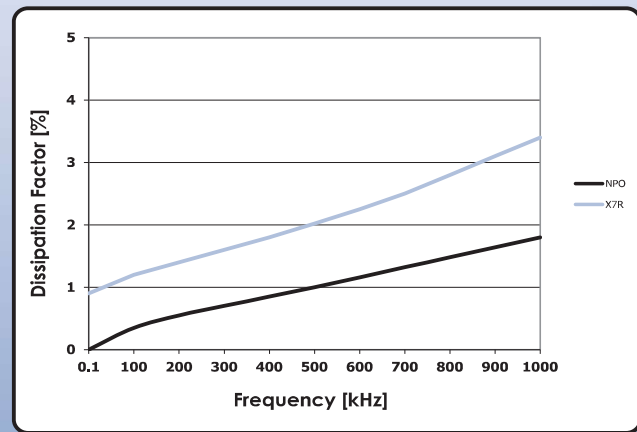

Dissipation Factor Vs Frequency